

SMART Gas Detector/Transmitter(4~20mA)

with built-in LCD & explosion proof

- Suction Type -

DA- 800



Best Detectors, Best Service



C-910C, Bupyeong Woolim Lion's Valley,
#425, Cheongcheon-Dong, Bupyeong-Gu, Incheon, Korea
TEL: +82-32-623-7507 FAX: +82-32-623-7510
E-mail: sales@gasdna.com | Web: www.gasdna.com

Contents

■ Introduction	page 3
■ Features	page 3
■ Specification	page 4
■ Terminal	page 5
■ Wiring	page 5
■ User programming	page 6
■ Dimension	page 14

[Introduction]

DA-800 detects various combustible, toxic and VOC gases leaked from industrial areas and display its density for gas producers, gas users, gas reservoirs, gas by-producers, and so on.

It is an indicator and transmitter type gas detector which converts detection signal into a standard current signal and transmit output to external devices.

Transmitter of DA-800 displays sensor's current and voltage signal by gas density on LCD, still converts into 4-20mA standard current output signal and transmit to external side.

4-20mA standard current output signal can be transmitted to various controller such as Gas leakage alarm system (GMS1000, GMS2000) PLC, DDC, MMR to build a integrated or individual gas monitoring system.

[Features]

- ◆ Built-in micro processor realizes various artificial intelligent functions which result in more convenient, more accurate, and more efficient gas detection environment.
- ◆ Built-in HD(high dissolution) A/D converter for accurate output signal.
- ◆ LOW/HIGH 2 step relay contacts (AL1/AL2) enable to interlock with a various external devices like FAN.
- ◆ 4-20mA output enables stable and long distance (maximum 2.5km) signal transmission.
- ◆ User programmable Menu offers to set user's own operating functions.

[Specification]

Segment	DA-800
Gas sampling	Suction type
Density display	LCD Display - PPM, %LEL , % (set by user)
Input power	DC 20~30V
Structure	Explosion proof
Target gas	Toxic, Combustible , O2, VOC(PID) (select)
Detection principle	Catalytic, Electro-Chemical, VOC(PID) ,NDIR (select)
Suction flow rate	0 ~ 1000ml/ min
Suction distance	Within 100m
Measurement range	Please refer to the target gas list (page 16)
Accuracy	≤ ±2%/Full Scale
Response time	Within 20 seconds, 90% / full scale
Sensor calibration	AUTO-CALIBRATION with Magnetic Switch
User programming	Calibration density & Measurement range
Wiring	CVVS & CVVSB 1.25sq*3wire
Output signal	4-20 ^{mA} DC/F.S // RS-485(MODBUS-RTU)
Alarm output	2 Step (HIGH/LOW) Alarm RELAY CONTACT
Operation Temperature	-10℃ ~ 50℃
Operation humidity	5 ~ 95%RH (Non-Condensing)
Wire conduit	1/2" or 3/4" PF,NPT
Housing material	Cast Aluminum Alloy
Mounting	Wall or Pipe Station

[Terminal]

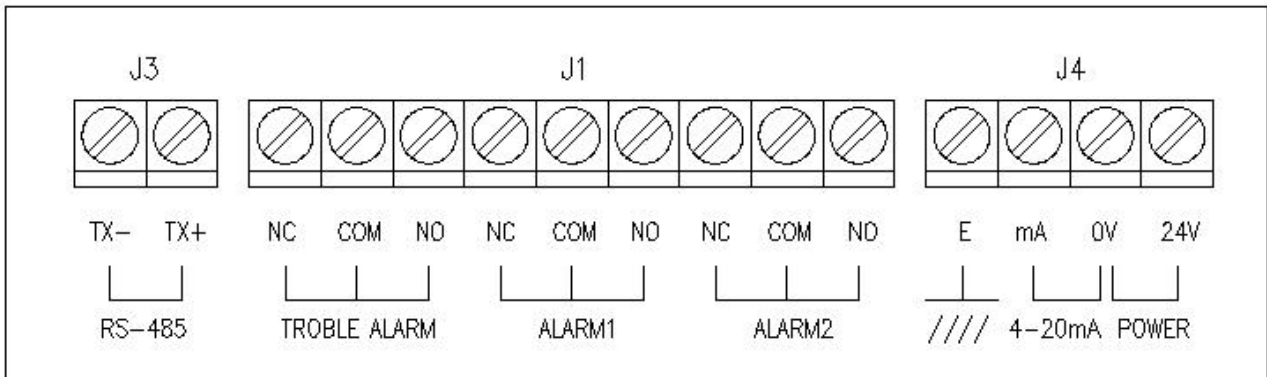

[WIRING]

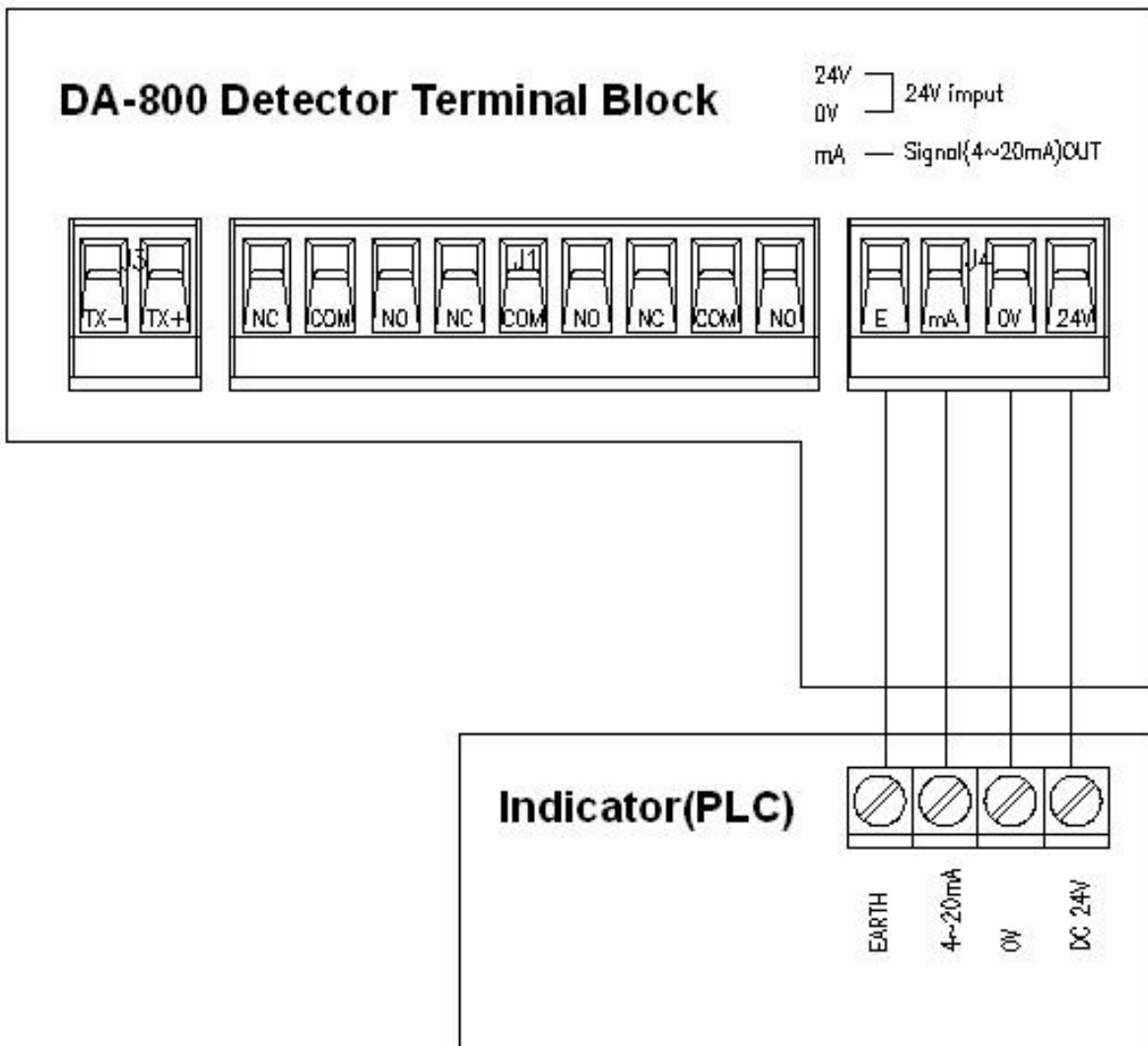

[User programming]

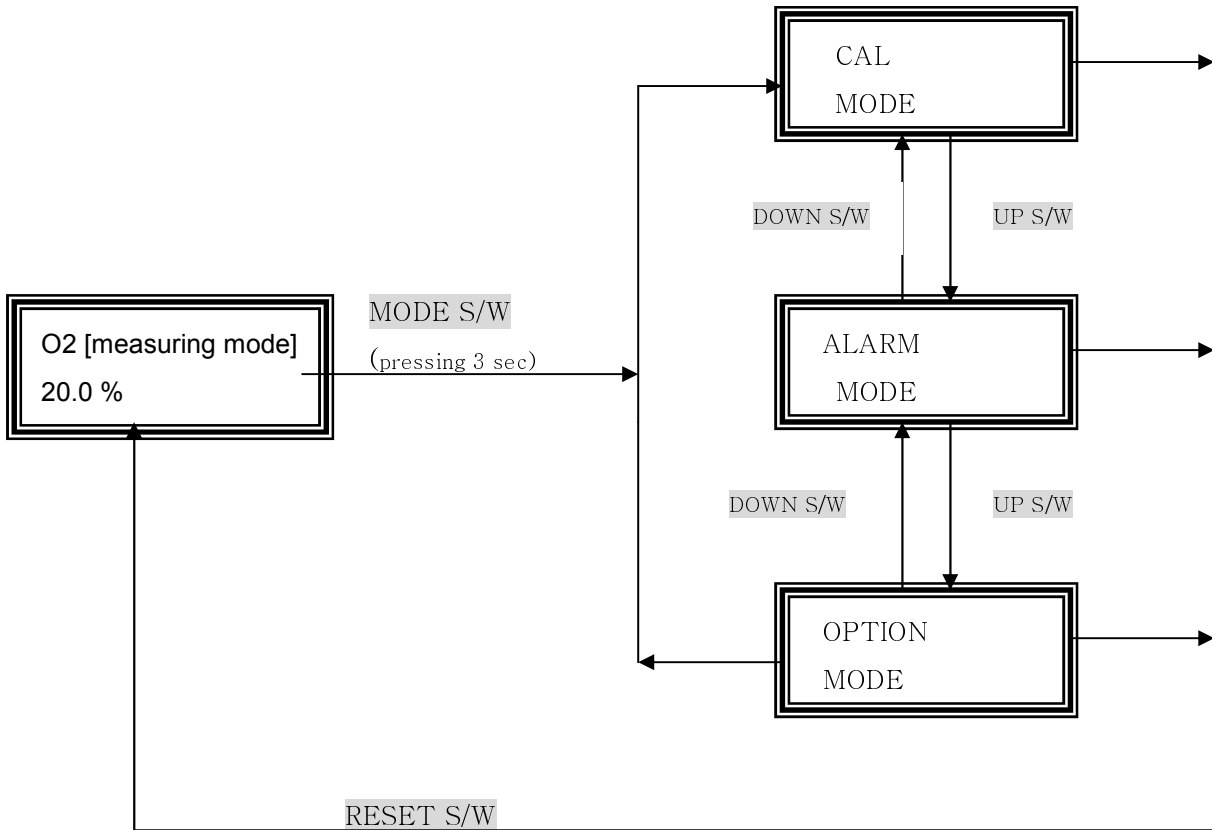

<1> CAL MODE

- Adjust zero calibration & span calibration for sensor calibration

<2> ALARM MODE

- Adjust setting value of alarm type, alarm 1, & alarm 2.

<3> OPTION MODE

- Adjust the other parameters

[1] CAL MODE

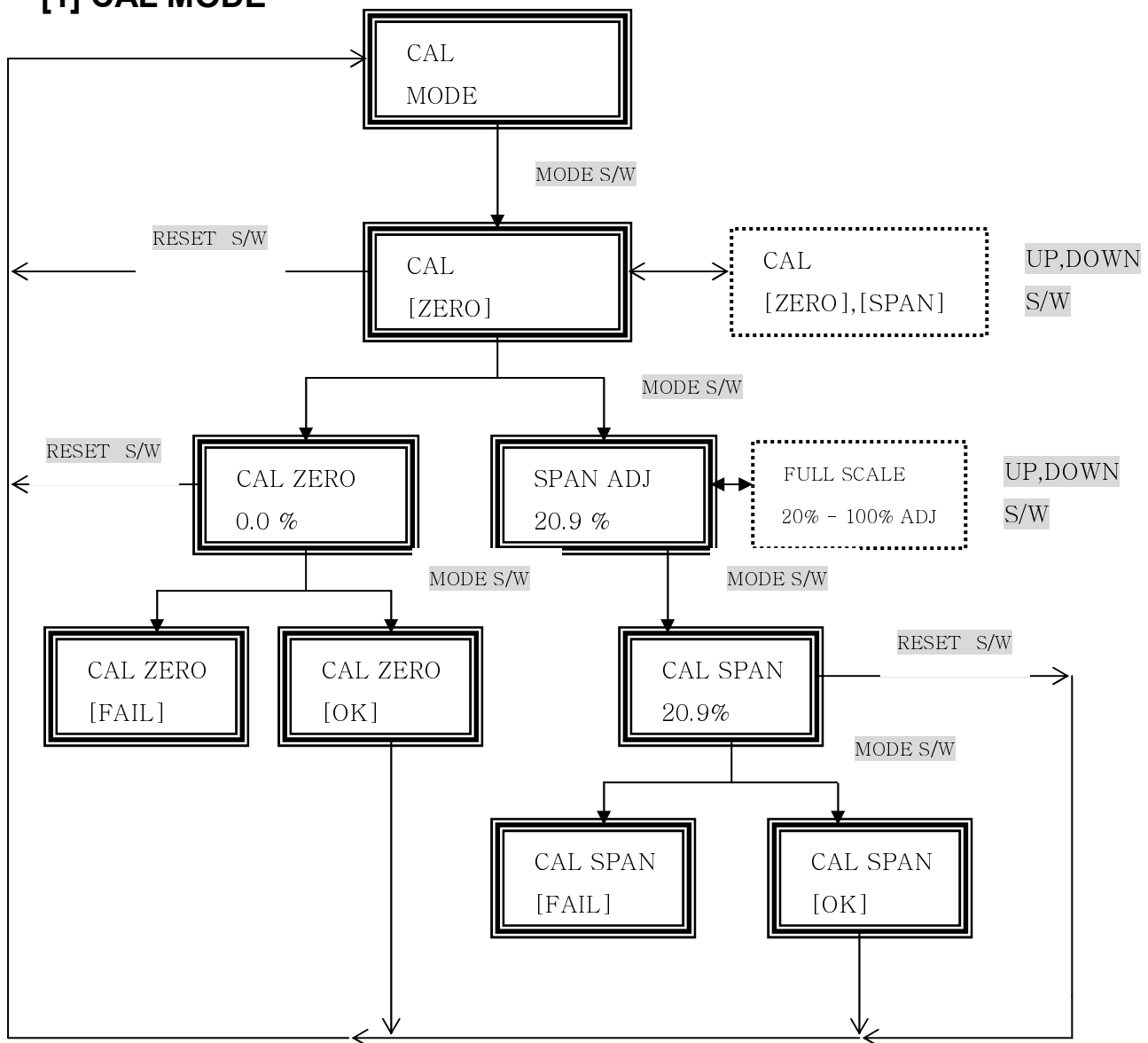

(1.1) Zero calibration

- ① At 'CAL [ZERO]', please press **MODE** key to start zero calibration. And then, "CAL ZERO <0.0%>" appears on the LCD.
- ② Please infuse the clean air or 100% nitrogen gas at 500ml/min flow rate until the displayed value is stabilized.
- ③ Please press **MODE** key to complete the zero calibration. And then, "CAL ZERO [OK]" appears on the screen. If the zero calibration is not successful, "CAL ZERO [FAIL]" will be appeared on the LCD during 2 seconds.

(1.2) Span calibration

- ① At 'CAL [SPAN]', please press **MODE** key to start span calibration. And then, "SPAN ADJ <20.9%>" appears on the LCD.
- ② Please press **UP, DOWN** key to input the standard gas value.
- ③ Please press **MODE** key to confirm it. And then, "CAL SPAN [20.9%]" appears on the LCD.
- ④ Please infuse the standard gas at 500ml / min flow rate during 1 minute.
- ⑤ Please infuse the standard gas during one(1) minute. And then, please wait until the displayed value gets stabilized.
- ⑥ When the displayed vale has been stabilized, please press **MODE** key. And then, "CAL SPAN [OK]" appears on the LCD. If the calibration is not successful, "CAL SPAN [FAIL]" will be appeared on the

LCD during 2 seconds.

[2] ALARM MODE

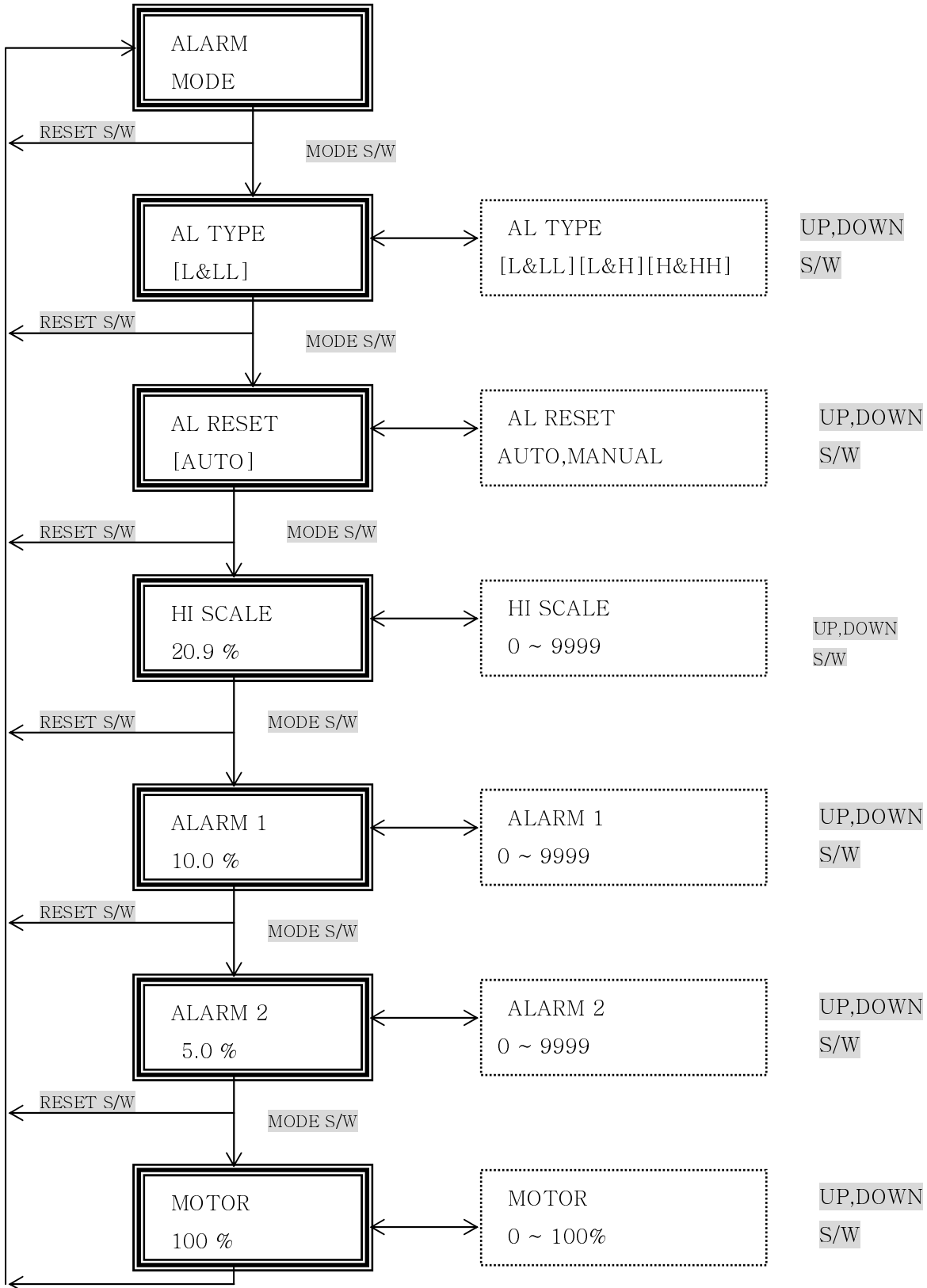

(2.1) AL TYPE (Select alarm type)

- It has Four(4) alarm types: L&L, L&H, H&L, and H&H
- You can use two alarm relay – relay 1 & relay 2.

(ex) If you set 'AL TYPE' to H&L:

- Relay 1- set high: when the measured value is higher than set value, alarm on.
- Relay 2 -set low: when the measured value is lower than set value, alarm on.

(2.2) AL RESET

- The method how to control ALARM Relay .

- Select 'AUTO' ↔ 'MANUAL'

<1> AUTO: The relay contact & Alarm LED releases according to set value automatically regardless of reset switch

<2> MANUAL: Only when you press reset switch, the relay contact & LED releases.

(2.3) HI SCALE

- Set 4 ~ 20mA output signal for full scale.

(ex) If you set SCALE to 100,

4mA output signal displays '0' and 20mA output signal displays '100'.

(2.4) ALARM 1

- According to 'AL TYPE', alarm #1 on.

(2.5) ALARM 2

- According to 'AL TYPE', alarm #2 on.

(2.6) MOTOR (Suction pump flow rate control)

- Set the flow rate from 0 to 100ml / min.
-

[3] OPTION MODE

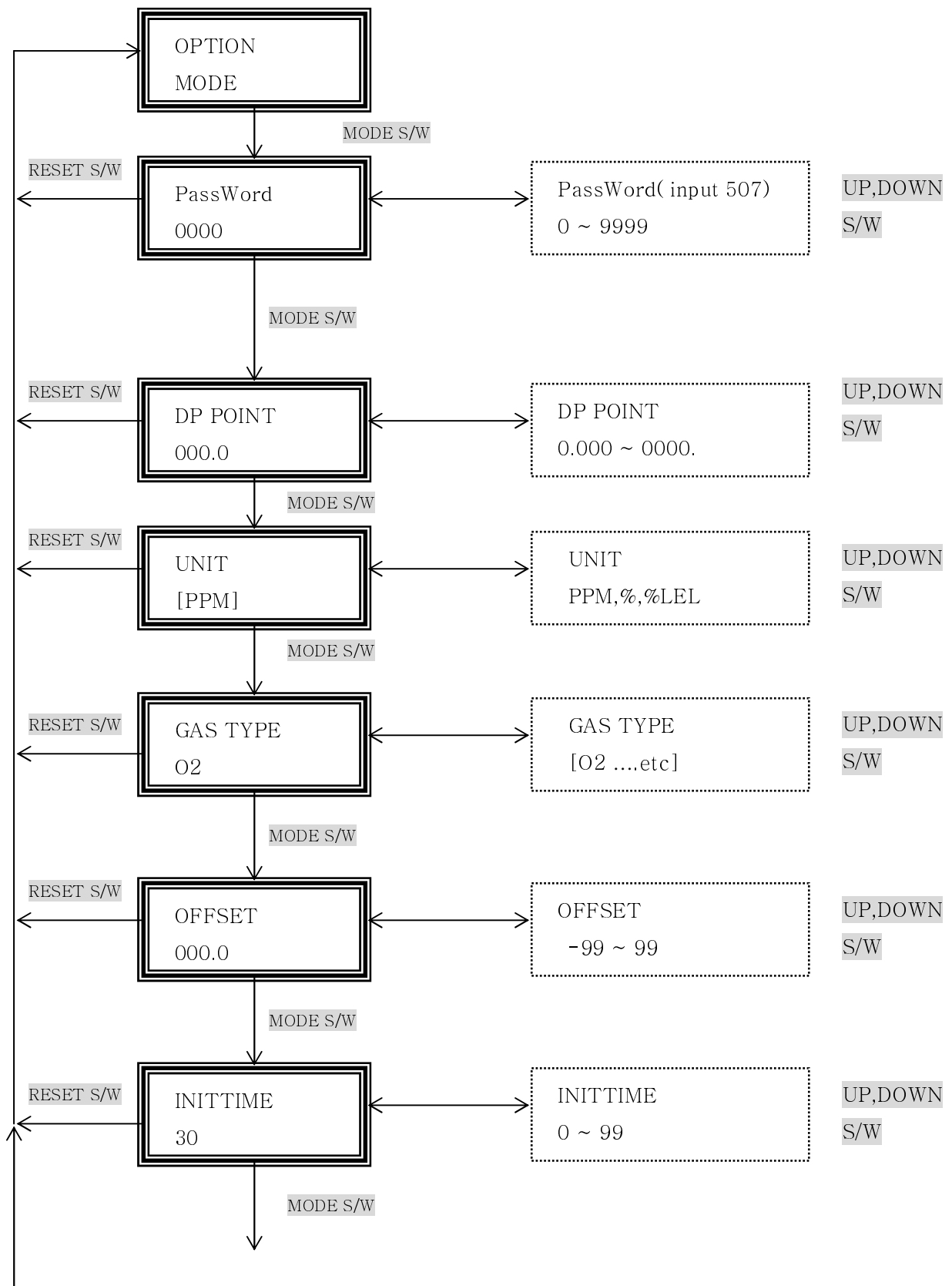

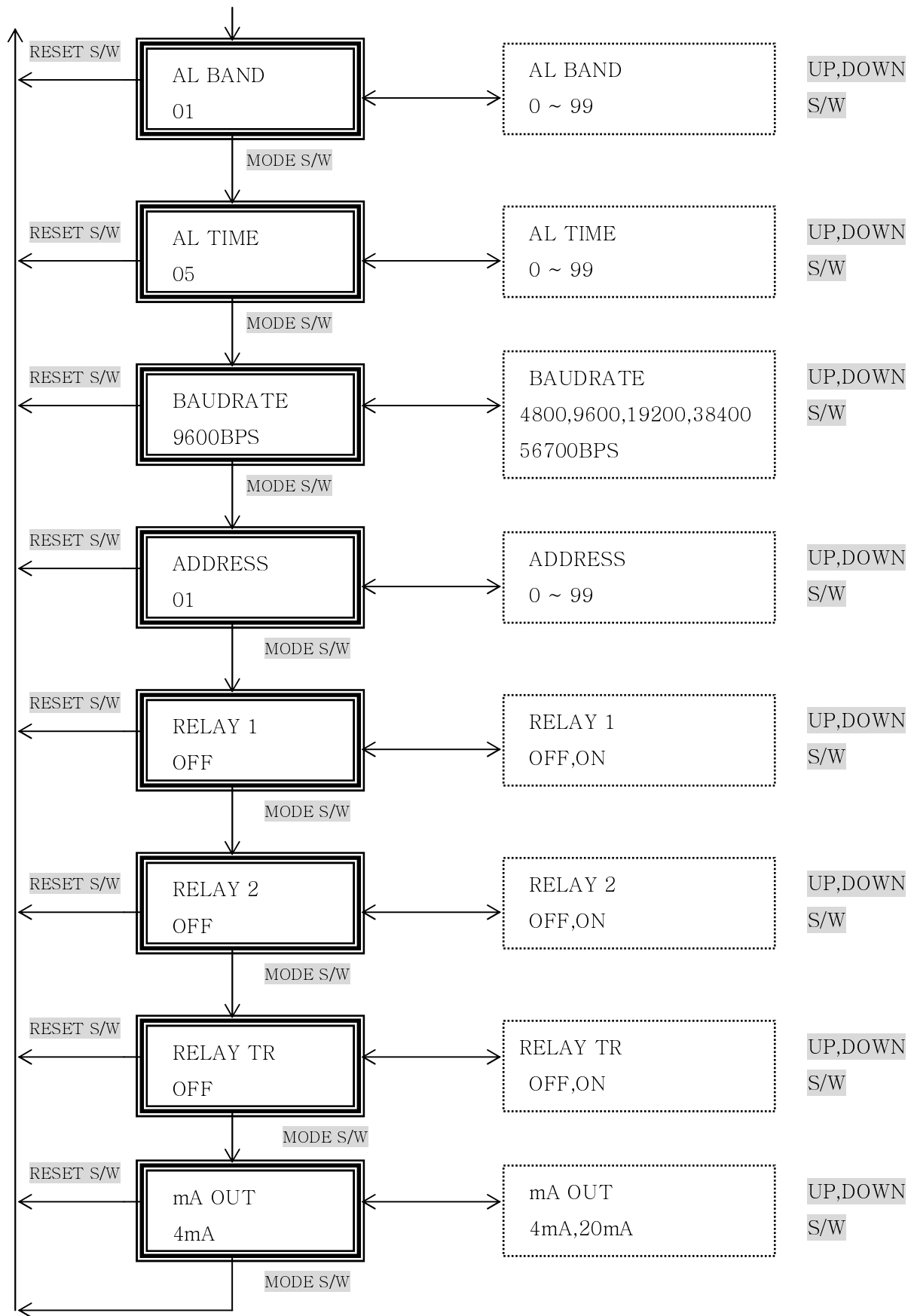

(*) 'OPTION MODE' is scarcely used. Please press password '507' to enter the 'OPTION MODE**

(3.1) DP POINT (Set decimal point of density values)

- Change decimal point according to the measurement range.

(3.2) UNIT(Select density unit)

- 3 options: %LEL, PPM, %.

(3.2) GAS TYPE(Display measuring gas)

- O₂, HCL, and so on.

(3.3) OFFSET(Compensation of measured value)

- Compensate the measured value.

(ex) OFFSET: If it sets '+5',

➔ When the measured value is '-5', it have to display -5. But it displays '0' after compensation of '+5'.

(3.4) INITTIME(Initialization time)

- After certain time from power on, sensor can provide stable output.

(3.5) AL-BAND(ALARM DEAD BAND)

Relay output usually repeats on/off around the alarm set value and it makes trouble. 'D-BAND' function gives hysteresis value on the alarm set value to remove this kind of trouble.

(ex1) If 'ALARM 1' sets 20, 'ALARM TYPE' sets 'H&H' & 'D-BAND' sets '3'

➔ When value displays higher than 20, alarm on ↔ lower than 17, alarm off.

(ex2) If 'ALARM 1' sets 20, 'ALARM TYPE' sets 'H&L' & 'AL-BAND' sets '3'

➔ When value displays lower than '20', alarm on ↔ higher than '23', alarm off.

(3.6) AL TIME (ALARM DELAY TIME)

This function is to prevent the normal operation of sensor against any momentary malfunctions affected by outside impact or noise.

(ex) When alarm value sets '50' & 'AL TIME' sets '5'.

➔ Only when the measured value keeps higher than alarm set value during longer than '5' seconds, alarm on.

(3.7) BAUDRATE

- Set RS-485 baud rate.

(3.8) ADDRESS

- Set RS-485 address.

(3.9) RELAY 1 [OFF]

- Self test mode to diagnose 'ALARM-1' relay output.

(3.10) RELAY 2 [OFF]

- Self test mode to diagnose 'ALARM-2' relay output.

(3.11) RELAY TR [OFF]

- Self test mode to diagnose 'ALARM TROUBLE' relay output.

(3.12) mA OUT

- Self test mode to diagnose analogue signal output.

-

[Dimension]

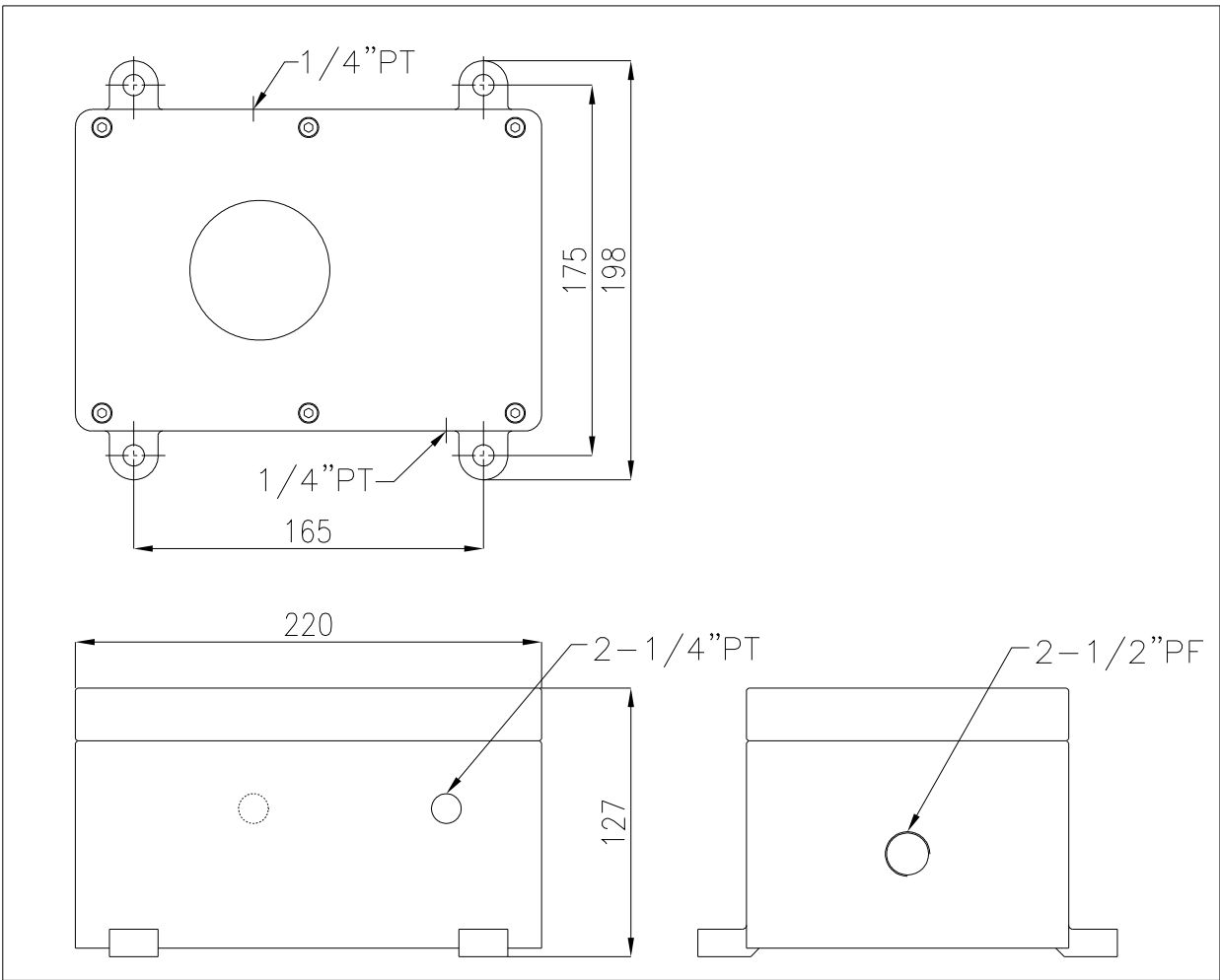

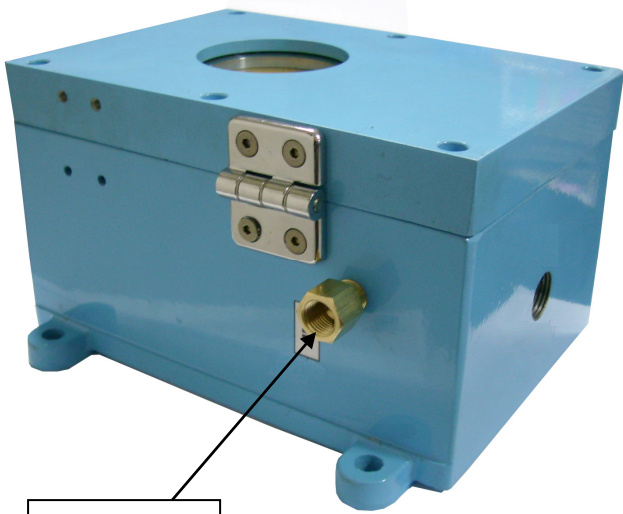

GAS IN

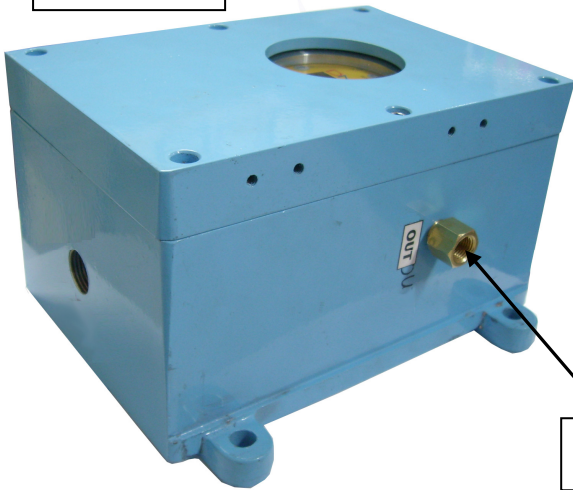

GAS OUT(1/4"PT)

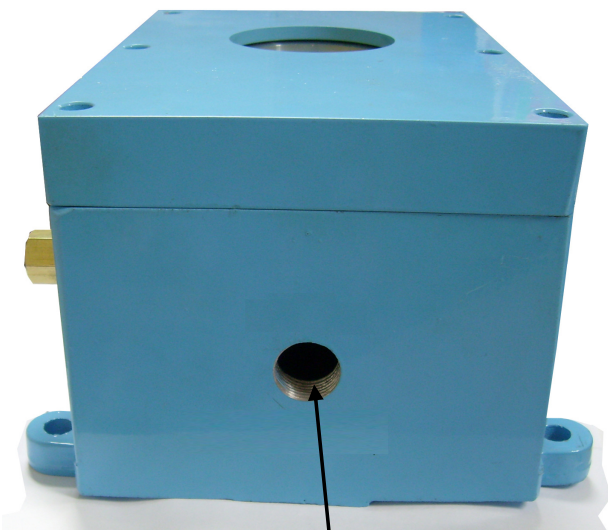

1/2"PF

DA-800 Toxic gas list

Target Gas	Formula	Measuring Range	Code Number
Acetaldehyde	CH ₃ CHO	0~500 ppm	DA-800-CH ₃ CHO
Ammonia	NH ₃	0~100 ppm	DA-800-NH ₃
Arsine	AsH ₃	0~1.00 ppm	DA-800-AsH ₃
Arsenic Trichloride	AsCl ₃	0~1.00 ppm	DA-800-AsCl ₃
Arsenic Trifluoride	AsF ₃	0~10.0 ppm	DA-800-AsF ₃
Arsenic Pentafluoride	AsF ₅	0~10.0 ppm	DA-800-AsF ₅
Boron Trichloride	BCl ₃	0~15.0 ppm	DA-800-BCl ₃
Boron Tribromine	BBr ₃	0~15.0 ppm	DA-800-BBr ₃
Boron Trifluoride	BF ₃	0~10.0 ppm	DA-800-BF ₃
Butanethiol	C ₄ H ₉ SH	0~10.0 ppm	DA-800-C ₄ H ₉ SH
Carbonyl Fluoride	COF ₂	0~10.0 ppm	DA-800-COF ₂
Carbon Dioxide	CO ₂	0~5000 ppm	DA-800-LCO ₂
Carbon Dioxide	CO ₂	0~5.00 %	DA-800-MCO ₂
Carbon Dioxide	CO ₂	0~100 %	DA-800-HCO ₂
Carbon Monoxide	CO	0~500 ppm	DA-800-CO
Carbon Tetrachloride	CCl ₄	0~30.0 ppm	DA-800-CCl ₄
Chlorine	Cl ₂	0~10.0 ppm	DA-800-Cl ₂
Chlorine Dioxide	ClO ₂	0~2.00 ppm	DA-800-ClO ₂
Chlorine Trifluoride	ClF ₃	0~2.00 ppm	DA-800-ClF ₃
Diborane	B ₂ H ₆	0~1.00 ppm	DA-800-B ₂ H ₆
Dichlorosilane	SiH ₄ Cl ₂	0~10.0 ppm	DA-800-SiH ₄ Cl ₂
Disulfur Decafluoride	S ₂ F ₁₀	0~10.0 ppm	DA-800-S ₂ F ₁₀
Disulfur Dichloride	S ₂ Cl ₂	0~10.0 ppm	DA-800-S ₂ Cl ₂
Flourine	F ₂	0~10.0 ppm	DA-800-F ₂
Formic Acid	HCOOH	0~500 ppm	DA-800-HCOOH
Germane	GeH ₄	0~1.00 ppm	DA-800-GeH ₄
Germanium Chloride	GeCl ₄	0~10.0 ppm	DA-800-GeCl ₄
Hydrazine	N ₂ H ₄	0~10.0 ppm	DA-800-N ₂ H ₄
Hydrogen	H ₂	0~2000 ppm	DA-800-H ₂
Hydrogen Bromide	HBr	0~10.0 ppm	DA-800-HBr

Hydrogen Chloride	HCl	0~10.0 ppm	DA-800-HCl
Hydrogen Cyanide	HCN	0~50.0 ppm	DA-800-HCN
Hydrogen Fluoride	HF	0~10.0 ppm	DA-800-HF
Hydrogen Sulfide	H ₂ S	0~100 ppm	DA-800-H ₂ S
Iodine ²	I ₂	0~10.0 ppm	DA-800-I ₂
Isopropanol ²	(CH ₃) ₂ CHOH	0~500 ppm	DA-800-(CH ₃) ₂ CHOH
Methanol ²	CH ₃ OH	0~500 ppm	DA-800-CH ₃ OH
Nitric Oxide	NO	0~100 ppm	DA-800-NO
Nitrogen Dioxide	NO ₂	0~20.0 ppm	DA-800-NO ₂
Nitrogen Trifluoride	NF ₃	0~30.0 ppm	DA-800-NF ₃
Oxygen	O ₂	0~30 % vol	DA-800-O ₂
Ozone	O ₃	0~1.00 ppm	DA-800-O ₃
Phosgene	COCl ₂	0~5.00 ppm	DA-800-COCl ₂
Phosphine	PH ₃	0~1.00 ppm	DA-800-PH ₃
Phosphorus Trichloride	PCl ₃	0~15.0 ppm	DA-800-PCl ₃
Phosphorous	PCl ₅	0~15.0 ppm	DA-800-PCl ₅
Phosphoryl Chloride	POCl ₃	0~10.0 ppm	DA-800-POCl ₃
Silane	SiH ₄	0~20.0 ppm	DA-800-SiH ₄
Silicon Tetrachloride	SiCl ₄	0~10.0 ppm	DA-800-SiCl ₄
Stibin ²	SbH ₃	0~1.00 ppm	DA-800-SbH ₃
Sulfur Dioxide	SO ₂	0~20.0 ppm	DA-800-SO ₂
Sulfuryl Fluoride ²	SO ₂ F ₂	0~10.0 ppm	DA-800-SO ₂ F ₂
Sulfur Tetrafluoride	SF ₄	0~9.00 ppm	DA-800-SF ₄
Trichlorosilane	SiHCl ₃	0~15.0 ppm	DA-800-SiHCl ₃
Thiophene	C ₄ H ₄ S	0~50.0 ppm	DA-800-C ₄ H ₄ S
Tin Tetrabromide	SnBr ₄	0~10.0 ppm	DA-800-SnBr ₄
Tin Tetrachloride	SnCl ₄	0~30.0 ppm	DA-800-SnCl ₄
Tin Tetrafluoride	SnF ₄	0~10.0 ppm	DA-800-SnF ₄
Titanium Tetrachloride	TiCl ₄	0~10.0 ppm	DA-800-TiCl ₄
Trichlorosilane	SiHCl ₃	0~10.0 ppm	DA-800-SiHCl ₃
Trichlorotriazine	C ₃ Cl ₃ N ₃	0~10.0 ppm	DA-800-C ₃ Cl ₃ N ₃
Trifluorotriazine	C ₃ F ₃ N ₃	0~10.0 ppm	DA-800-C ₃ F ₃ N ₃

DA-800 Combustible gas list

Target gas	Formula	Explosion limit (%VOL)
Acetaldehyde	CH ₃ CHO	4
Acetic acid	CH ₃ COOH	4
Acetone	CH ₃ COCH ₃	2.5
Acetylene	C ₂ H ₂	2.5
Bezene	C ₆ H ₆	1.5
Butane	C ₄ H ₁₀	1.86
Chloro benzene	C ₆ H ₅ Cl	1.3
Cyclohexane	C ₆ H ₁₂	1.3
Di-Methylethar	CH ₃ OCH ₃	2
Ethane	C ₂ H ₆	3.22
Ethanol	CH ₃ CH ₂ OH	3.6
Ethylene	C ₂ H ₄	2.75
Ethylene glycol (EG)	HOCH ₂ CH ₂ OH	3.2
Ethylene oxide (EO)	C ₂ H ₄ O	3.0
Formic acid	CH ₂ O ₂	16.9
Gasoline		1.4
Heptane	CH ₃ (CH ₂) ₅ CH ₃	1.05
Hydrogen	H ₂	4
Iso-butane	i-C ₄ H ₁₀	1.8
Iso-propyl alcohol	(CH ₃) ₂ CHOH	2
Methane	CH ₄	5
Methyl alcohol	CH ₄ O	7.3
Methyl bromide	CH ₃ Br	1
Naphthalene	C ₁₀ H ₈	0.9
Octane	CH ₃ (CH ₂) ₆ CH ₃	1
Pentane	CH ₃ CH ₂ CH ₂ CH ₂ CH ₃	1.5
Phenol	C ₆ H ₅ OH	1.3
Propane	C ₃ H ₈	2.1
Propylene	C ₃ H ₆	2
Propylene oxide (PO)	C ₃ H ₆ O	2.3
Thinners		1
Toluene	C ₇ H ₈	1.2
Vinyl acetate (VAM)	CH ₂ =CHOCOCH ₃	2.6
Vinyl chloride	CH ₂ =CHCl	3.6

Xylene	$C_8H_{10}=C_6H_4[CH_3]_2$	1.1
--------	----------------------------	-----

***For other gases(unlisted gases), Please contact us.**